

# Technical Report Three

## Mechanical Systems and Existing Conditions Evaluation

---

12.01.2009

# Defense Media Activity Building

Fort George G. Meade



**Pavel Likhonin**

**Penn State University**

**Architectural Engineering**

**Mechanical Option**

**Faculty Advisor: Dr. Treado**

# Table of Contents

## Table of Contents

Table of Contents .....	2
Executive Summary .....	3
Mechanical System Description .....	4
Introduction .....	4
Design Objectives and Requirements .....	4
Site and Budget .....	4
System Initial Cost .....	4
Lost Space .....	5
Energy Sources .....	5
Design Air Conditions .....	6
Equipment Summaries .....	6
System Operation .....	9
Schematics .....	9
Air Side .....	13
Water Side .....	14
Chilled Water .....	14
Hot Water .....	14
Data Found in Previous Technical Reports .....	15
Ventilation Requirements .....	15
Heating and Cooling Loads .....	16
Annual Energy Use .....	17
LEED Analysis for the Mechanical Systems .....	20
Energy and Atmosphere .....	20
Indoor Environmental Quality .....	21
Overall Evaluation .....	22

## Executive Summary

Technical Report Three summarizes the intent, the function, and the design of mechanical systems in the DMA Building. It also provides an overall evaluation and operation of the building.

DMA uses a Variable Air Volume (VAV) system to condition the building as well as high density APC cooling racks to cool the data center. The DMA Building is cooled mechanically using three centrifugal chillers which are water cooled by three cooling towers. The pumping distribution of the chilled water is a primary/secondary flow system where the flow through the chillers and the flow to the building loads are separated by a decoupling line. Three natural gas condensing boilers are used to heat the building and provide domestic hot water. All of the systems are connected and controlled using LonWorks language DDC controls.

When designing this building, energy efficiency was a big concentration during the design to meet LEED Certification. Operation of the building was also a large factor which had to be considered when designing this building. This building is operated around the clock, and redundancy is a must. Many of the systems are backed up with redundant equipment which can be remotely monitored and operated in case of emergencies.

The HVAC systems estimated cost for the DMA Building was around \$13,466,024. The operation of this building as reported in Technical Report Two is around \$5.03/ft<sup>2</sup> a year. The data center consumes around 42% of the total energy in the building which is about 67% of the total cost.

The mechanical system picked for the DMA Building is conventional by design and is relatively easy to maintain. It uses energy efficient equipment, making the DMA Building energy efficient as well as satisfying energy, thermal comfort and ventilation standards. It is controlled by DDC in order to achieve the best control as well as making sure that the system can be operated without interruption and at an efficient state.

# Mechanical System Description

## Introduction

Defense Media Activity is a 3 story, 186,000 square foot facility designed for the Army Corps of Engineers. This building has a data center, television studios, media centers, offices, and editing suites. The DMA Building will operate 24 hours a day which separates it from a typical office building. It is designed to operate with redundancy in mind, as well as efficiency for LEED Certification.

## Design Objectives and Requirements

The main design objectives for the DMA Building are as follows; meeting the ASHRAE Standards and earning LEED certification as a government requirement. Based on these standards, the building must meet energy, ventilation, temperature, and humidity requirements. With these requirements in mind, the design produced an energy efficient building using a conventional Variable Air Volume (VAV) system to condition the building. The mechanical system consists of high efficiency chillers, cooling towers, and boilers to condition the building as well as high density APC cooling racks to take care of the data center loads.

## Site and Budget

The site for the DMA building is located in Fort George G. Meade, Maryland. Fort Meade is one of the largest Army installations in the US. It is currently expanding to accommodate the Base Realignment and Closure (BRAC) plan. The current site of the DMA Building is on a golf course that is being prepared for construction. Special storm water permits and wetland waterway permits had to be obtained for site work in order to prevent erosion and provide sediment control. **The budget for the DMA Building was around \$84.76 million.** The building was bid and awarded for \$56,195,000 which was within the budget. The building was designed to be energy efficient while keeping budget in mind. The current economic situation certainly helped in keeping the building within the original budget.

## System Initial Cost

The estimated cost for the HVAC system in the DMA Building is about \$13,466,024. That is about \$75.37 per square foot of area. The estimated cost for plumbing is about \$807,990 which is around \$6.65 per square foot. When comparing the total estimated cost of the HVAC system, the construction cost for the mechanical system about 18% of the total cost.

## Lost Space

The lost space due to mechanical equipment is summarized by floor in Table 1. Every floor has a mechanical room with two AHU's. The first floor contains chillers and boilers which adds additional space to the mechanical rooms. All of the shafts in the building are located in the mechanical rooms, and therefore no additional area has been taken by the mechanical system.

Table 1

Mechanical Spaces	
Floor	Lost Space (SF)
Ground	4,681
1st	5,332
2nd	1,182
<b>Total</b>	<b>11,196</b>

## Energy Sources

The site doesn't have district cooling or heating available. The energy sources that are available for the DMA Building are two electrical feeds and a natural gas line. The utility providing these sources is Baltimore Gas and Electric. The rates used for analysis are provided in Technical Report Two, as well as listed in Table 2.

Table 2

Baltimore Gas and Electric Rates		
Electricity	Demand Charge (\$/kW)	3.95
	Peak (cents/kWh)	11.551
	Mid-Peak (cents/kWh)	9.265
	Off-Peak (cents/kWh)	8.824
Gas	Up to first 10000 therms (\$/therm)	0.1975
	Above 10000 therms (\$/therm)	0.0948

## Design Air Conditions

Fort George Meade is located just outside of Baltimore, MD so the design conditions for Baltimore were used in the building model. The design outdoor air conditions for Baltimore, MD were obtained from the ASHRAE Fundamentals 2005. The coldest month was January and the hottest month was July. These values are shown in Table 3 below.

Table 3

ASHRAE Design Conditions for Baltimore, MD		
Summer		Winter
DB (F)	MCWB (F)	DB (F)
93.6	75	12.3

The design indoor air conditions for the DMA Building were obtained from the designer. These values can be seen in Table 4 below.

Table 4

Indoor Conditions	
Cooling Setpoint	75 F
Heating Setpoint	68 F
Relative Humidity	50%

## Equipment Summaries

The majority of the DMA Building is conditioned by a Variable Air Volume (VAV) system. There are a total of 168 terminal units in the building. These terminal units are connected to 6 Air Handling Units (AHU's) with 2 units per floor. The rest of the ventilation is done with 9 Roof Top Units. The AHU's and RTU's can be seen in Table 5.

Table 5

Airflow Rates		
Unit	Design Max CFM	Design Min OA
AHU-EG-1	12455	2380
AHU-EG-2	12070	1580
AHU-E1-2	15810	1800
AHU-E1-1	17660	2590
AHU-E2-1	12350	1460
AHU-E2-2	16710	2120
RTU-W1-1	3190	340
RTU-W1-2	9810	2580
RTU-W1-3	12895	3100
RTU-W1-4	14000	1400
RTU-W1-5	9200	480
RTU-W1-6	4700	450
RTU-W1-7	4910	470
RTU-W1-8	15890	4560
RTU-W1-9	22930	1200

The water side of the mechanical system uses a primary/secondary flow system with two sets of pumps. One set is dedicated to pumping refrigerant through the chiller, and the second set distributes the refrigerant throughout the building. The DMA Building uses three 500 ton centrifugal chillers which can be seen in Table 6. The condenser water is then pumped to the three cooling towers. Cooling towers are double cell induced draft. They can be seen in Table 7.

Table 6

Chillers											
Chilled Water									Condenser Water		
Unit	Tons	GPM	IPLV kW/ton	75% Load kW/ton	50% Load kW/ton	25% Load kW/ton	L.W.T. (F)	E.W.T. (F)	GPM	L.W.T. (F)	E.W.T. (F)
1	500	1000	0.356	0.418	0.304	0.39	45	85	1500	85	95
2	500	1000	0.356	0.418	0.304	0.39	45	85	1500	85	95
3	500	1000	0.356	0.418	0.304	0.39	45	85	1500	85	95

Table 7

Cooling Towers				
Unit	GPM	Fan HP	E.W.T.	L.W.T
1	1500	25	95	85
2	1500	25	95	85
3	1500	25	95	85

Three natural gas condensing boilers which are 98% efficient are used to heat the building. These boilers and their specific data can be seen in Table 8.

Table 8

Boilers				
Unit	Type	Capacity (MBH)	GPM	Supply Temp (F)
1	Condensing	3000	150	180
2	Condensing	3000	150	180
3	Condensing	3000	150	180

Pumps are a major component of the mechanical system. Most of the pumps used in the DMA Building are variable frequency drive except for the primary side of the chilled water system. Each set of pumps for the chilled water and hot water systems consists of 3 variable frequency drive pumps. Two pumps are dedicated for the heat exchangers. The details of the pumps can be seen in Table 9.



Table 9

Pumps				
Description	Capacity	Head (ft)	HP	RPM
Primary Chilled Water	1000	40	15	1750
Primary Chilled Water	1000	40	15	1750
Primary Chilled Water	1000	40	15	1750
Secondary Chilled Water	2000	60	40	1750
Secondary Chilled Water	2000	60	40	1750
Secondary Chilled Water	1000	60	20	1750
Condenser Water	1500	50	30	1750
Condenser Water	1500	50	30	1750
Condenser Water	1500	50	30	1750
Primary Hot Water	150	40	3	1750
Primary Hot Water	150	40	3	1750
Primary Hot Water	150	40	3	1750
Secondary Hot Water	300	60	10	1750
Secondary Hot Water	300	60	10	1750
Secondary Hot Water	150	60	7.5	1750
Heat Exchanger	1000	25	10	1150
Heat Exchanger	1500	55	30	1770

## System Operation

### Schematics

Figure 1 shows the cooling tower flow. Cooling Tower 1 (CT-1) is the only tower that is used for waterside free cooling. Water side free cooling was done specifically for the data center. This was done in order to help reduce the large cooling loads from the data center. The rest of the building was not considered for waterside free cooling.

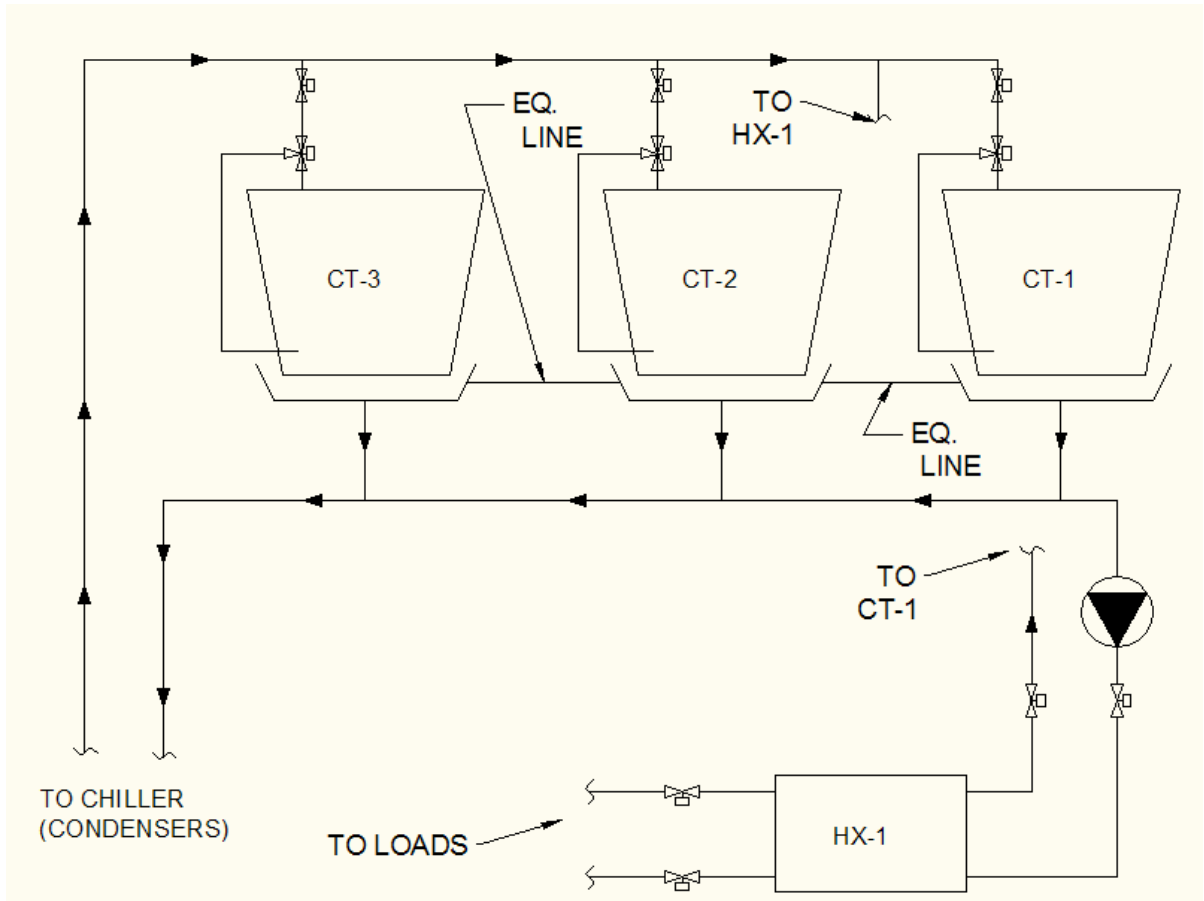

Figure 1

Figure 2 shows the condenser water going up to the cooling towers.

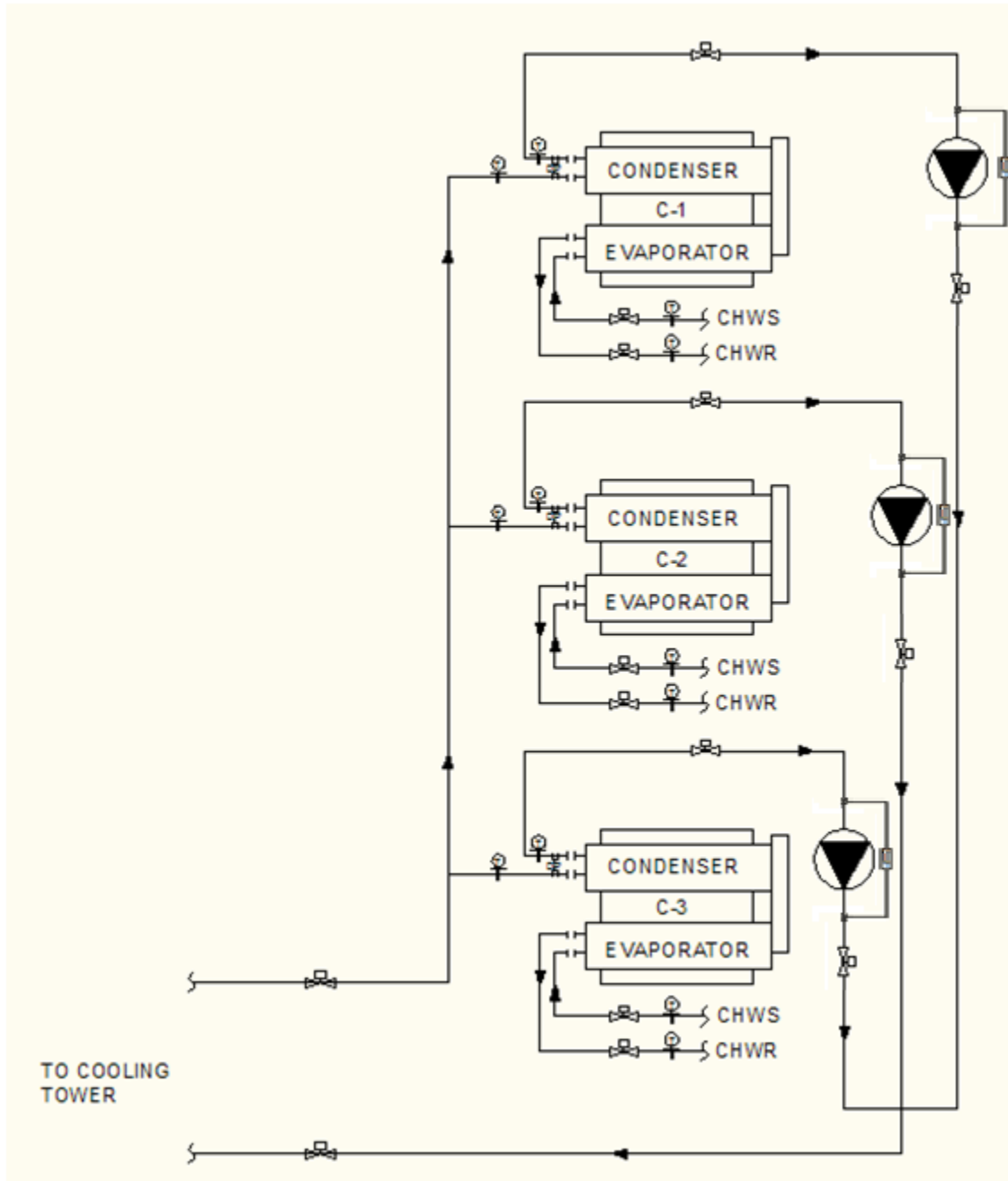

Figure 2

Figure 3 shows the chilled water system and the primary/secondary flow pumping system.

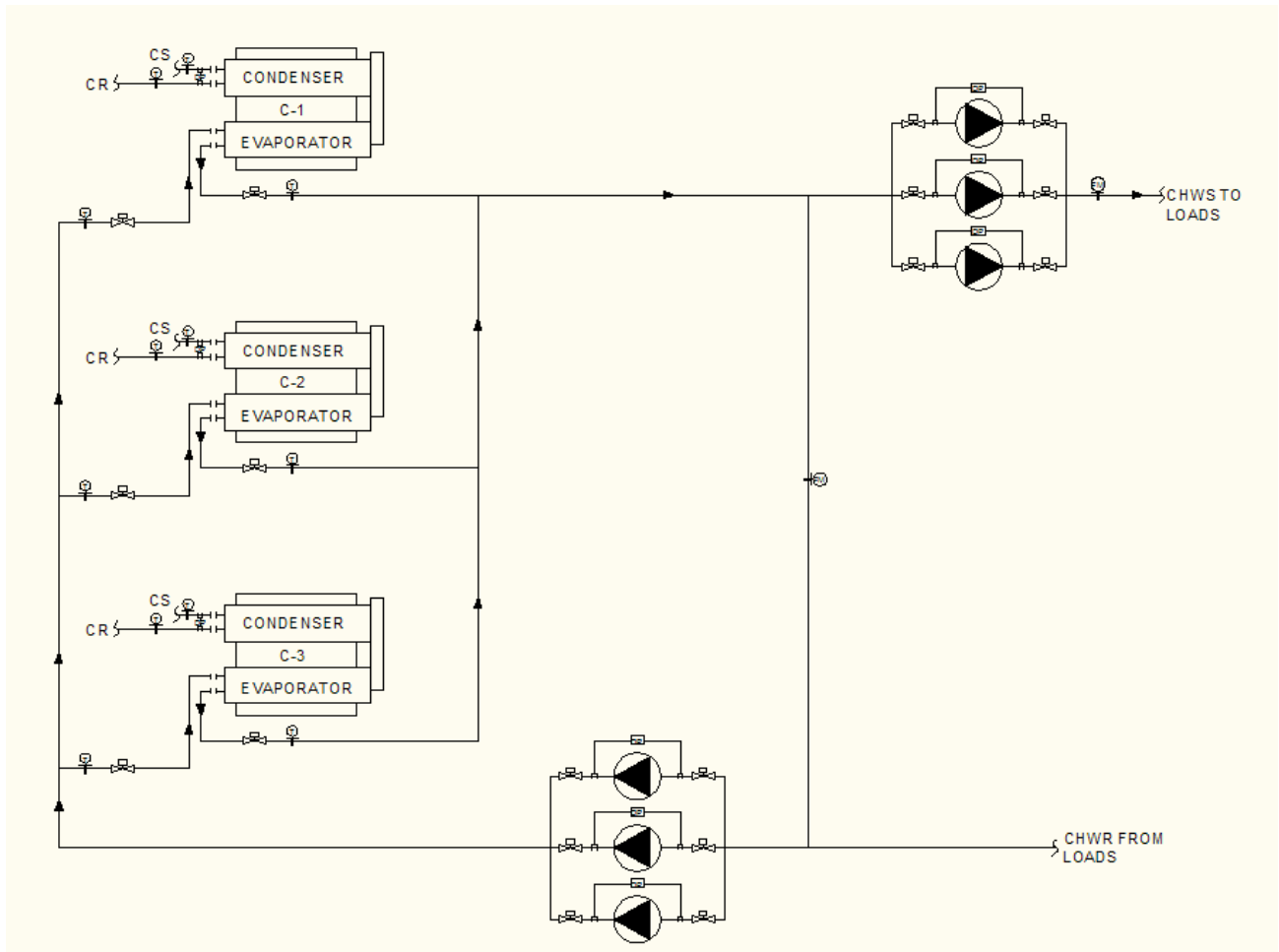

Figure 3

Figure 4 shows the hot water system.

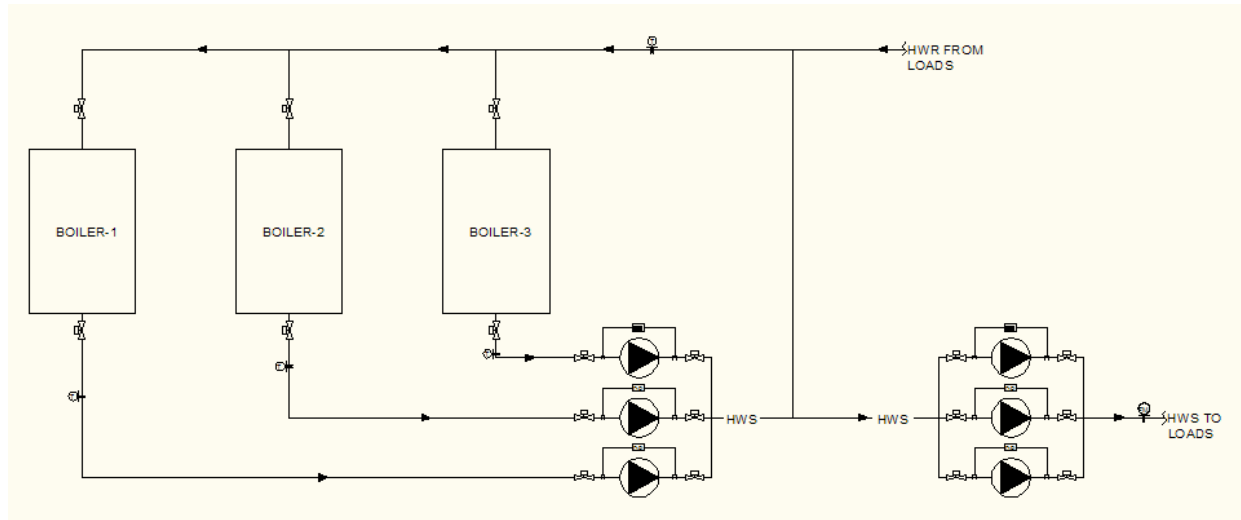

Figure 4

## Air Side

The DMA Building uses a VAV system. Each terminal unit is supplied with air from an AHU. Variable Speed Drive supply fans in the AHU's will automatically start based on the optimum time for warming up or cooling down based on a DDC control system which will use temperatures and operation schedules to determine this optimum time. The DDC system will control the pressurization of the building by varying the supply and exhaust fans until an appropriate pressure is obtained. Minimum outside air will be maintained at all times. Humidity and temperature sensors will tell the DDC system to modulate supply air to meet the cooling or heating loads of the building. During cooling mode, the maximum air temperature will be kept at 56 F and a minimum of 48 F. During an Economizer mode, the outside air will be modulated up to 100 percent open to condition spaces.

## Water Side

### Chilled Water

The DMA Building uses a chilled water system utilizing water cooled centrifugal chillers. Chillers use a DDC system control. Using this system control, allows for remote monitoring. This system will also allow chillers to be remotely operated including shut downs and starts. As mentioned earlier in the report, the chilled water system uses a primary/secondary flow system. The primary chilled water pumps will provide water to each evaporator, while the secondary chilled water pumps will distribute the chilled water throughout the system.

The master control panel sequences and controls each chiller to maintain a supply temperature of 45 F. Each pump is associated with its own chiller and staged at the same time the chillers are turned on. The lag chiller will be turned on once the lead chiller reaches 85% of capacity. Capacity is measured by the temperature difference between the supply and return. This can be seen on the schematic with temperature sensors located on the supply and return. To measure capacity, a flow meter is used on the secondary side as well as the decoupling line. Chillers are rotated automatically from lead to lag. Time delays are also built in for sequencing chillers on or off. This is done to prevent cycling when loads vary slightly below and above the capacity at which chillers are staged.

For redundancy, the secondary pumps are sized for 50% of the load and the third pump is on standby. Upon failure of a pump, the standby pump is automatically turned on. Condenser pumps are also monitored with pressure sensors in case of failure. These pressure sensors can be seen in Figures 3 and 4.

Cooling towers are controlled to keep the condensing water temperature at 85 F. Cooling tower fans are variable speed to control capacity more closely. Another feature built into the cooling towers is keeping the condensing water temperature at 65 F for partial free cooling and for full free cooling for cooling tower 1. If the temperature drops below 40 F, waterside free cooling is enabled. Once waterside free cooling is enabled, the pumps for the heat exchanger are staged on and isolated with cooling tower 1. If needed, a sump heater will be utilized to keep the water from freezing.

### Hot Water

When the outside temperature falls below 45 F the secondary heating pumps will run continuously. The outside air temperature also determines the number of boilers running. Secondary pumps are variable frequency drive and are modulated by the DDC control system.

Constant downstream differential pressure is maintained through the DDC system by monitoring the pressure with pressure sensors as seen in Figure 4.

## Data Found in Previous Technical Reports

Previous Technical Reports covered the information required for this report. The repeat areas include ASHRAE 62.1, ASHRAE 90.1 and Building Load Analysis.

### Ventilation Requirements

To verify the building air handling system provides enough ventilation air based on occupancy, a ventilation rate calculation procedure listed in ASHRAE 62.1 was performed. Ventilation rates were calculated for the majority of the building. The DMA Building has several different types of occupancies that include media centers, television studios, editing suites, and offices.

The calculations performed include all critical spaces in the building such as television studios, offices, media centers, and data centers. A total of 7 zones were checked for compliance with minimum airflow rates in different zones. Picking critical zones of the building should represent the rest of the building and its compliance or non-compliance of Section 6 of ASHRAE Standard 62.1.

The maximum  $Z_p$  values for the DMA building come from larger spaces that had a relatively small supply of total air and from offices that had large occupancies. Using default ASHRAE Standard values for occupancy may not be completely true. The actual occupancy may be lower once the rooms are outfit by the owner.

Another interesting finding is the slight deviation of Outside Air Requirement from the actual design. A possible reason for this non-compliance is the use of higher default occupancy values in the calculations. The AHU's may need to be re-sized or adjusted for higher airflow rates if the occupancy values stay true. Table 10 shows the design airflow rates as compared to the ASHRAE calculation.

Table 10

Airflow Rates				
Unit	Design Max CFM	Design Min OA	ASHRAE 62.1 Min OA	Compliance
AHU-EG-1	12455	2380	2924	No
AHU-EG-2	12070	1580	1338	Yes
AHU-E1-2	15810	1800	3159	No
AHU-E2-2	16710	2120	3761	No
AHU-E1-1	17660	2590	4022	No
AHU-E2-1	12350	1460	2070	No
RTU-W1-9	22930	1200	1198	Yes

Units B and K comply with the ASHRAE Standard 62.1 requirements for minimum outside air. The rest of the units (A, E, G, H and J) will need to be adjusted to meet the minimum outside air requirements to be compliant with Section 6. Once that is done, the DMA Building is compliant with ASHRAE Standard 62.1.

## Heating and Cooling Loads

The entire building was modeled and simulated in Trane TRACE 700. For the purpose of this report, (6) main air handlers will be discussed to the original design because the rest of the building follows the same trend. Table 11 below summarizes the space cooling SF/ton, heating Btuh/SF, total supply air CFM/SF, and ventilation supply as a percentage for the designed vs. modeled zones. The rest of the zones share a similar pattern as seen from the total building energy consumption later in the report when compared to the design.

Table 11

Comparison of Loads and Ventilation Indices									
AREA (SF)	Zone (AHU)	Cooling SF/ton		Heating Btuh/SF		Supply CFM/SF		Ventilation %OA	
		Design	Modeled	Design	Modeled	Design	Modeled	Design	Modeled
12672	A	513.66	583.65	13.63	13.36	0.95	0.53	13.09	22
16000	B	623.30	554.54	8.08	13.84	0.78	0.57	19.10	21.2
19532	D	430.79	360.67	14.33	19.72	0.90	1.04	14.67	38.9
19748	E	428.28	352.84	15.16	19.12	0.85	1.2	12.69	11.6
16648	F	510.05	446.64	11.83	17.2	0.74	0.7	11.82	18.4
18363	G	516.98	385.09	12.84	19.12	0.86	0.74	11.38	21.6



When comparing the design versus modeled cooling loads, there is a slight deviation from space to space. There is no significant trend of the modeled loads being mostly smaller or larger than the design. Some of spaces, such as Zone A, have a higher modeled square foot per ton while others, like Zone B, have a lower square foot per ton value. This deviation may come from slightly different areas used for the model. Another difference for this deviation is the modeling technique and the use of different software. The final design analysis for the DMA Building was done in eQuest with a room by room model. eQuest uses a different interface than TRACE and is a different modeling program so there is an expectation of differences in loads. The biggest contribution to this deviation of loads is probably the use of block loads instead of a room by room building analysis which was done by the designer.

Heating loads for the model were generally higher than the designer's loads. This is an interesting observation for the main AHU's because the total heating use of the model was lower than the design. The other areas of the building such as the warehouses and mechanical rooms in the model had much lower heating values than the design which lowered the heating energy use.

In general, the modeled building was relatively close to the design. The biggest difference between the modeled building and the design is the modeling method used. The designed building calculated loads room by room, while the modeled building used block loads, where multiple rooms with same functions were combined.

## Annual Energy Use

A designed and baseline energy figures were available from the LEED submission for EA Credit 1. Table 12 below shows the total energy consumption per year split up based on different types of loads in the building. Here you can see the comparison between the modeled (block loads), designed, and baseline building energy usage per year. Data Center energy consumption was added in after the model was created. This value was provided by the engineers based on the energy consumption of cooling racks.

Table 12

Annual Energy Consumption			
	Modeled	Designed	Baseline
Space Heating	1,937 (MBtu)	3,173 (MBtu)	4,433 (Mbtu)
Space Cooling	1,044,978 (kWh)	1,280,000 (kWh)	2,945,750 (kWh)
Lighting	705,581 (kWh)	834,000 (kWh)	932000 (kWh)
Pumps	154,484 (kWh)	366,000 (kWh)	388,000 (kWh)
Fans	834,583 (kWh)	291,000 (kWh)	701,500 (kWh)
Heat Rejection	8,760 (kWh)	7,000 (kWh)	4,000 (kWh)
Receptacle	1,832,882 (kWh)	826,000 (kWh)	826,000 (kWh)
Data Center	9,364,000 (kWh)	9,364,000 (kWh)	9,364,000 (kWh)
Water Heating	155 (Mbtu)	155 (Mbtu)	155 (Mbtu)

From this analysis, the biggest consumer of energy is the Data Center, followed by Space Cooling. Several large differences can be seen in the Modeled versus Designed buildings. Space heating is lower by 30% in the modeled as compared to the designed. Several attempts were made to raise the space heating value with very little success. After spending an hour on the phone with Trane and a whole day trying to close the gap between the designed and modeled buildings, 30% difference between the loads was the best scenario. The file somehow got corrupted and raising infiltration or the set point temperature only lowered the consumption for space heating.

Space Cooling was lower than the Designed, but much closer to the design value than Space Heating. Lighting was also a little bit lower as well as the pumps. Fans on the other hand were much higher energy consumer than the design as well as receptacles. The reason for high receptacle consumption is the type of function of this building. DMA is a media building with television studios, media centers, editing suites, control rooms, and offices. All of the DMA equipment was modeled as a receptacle load.

Figure 5 shows the calculated/modeled percentage of energy use in the DMA Building. The data center is consuming 42% of the building's total energy.

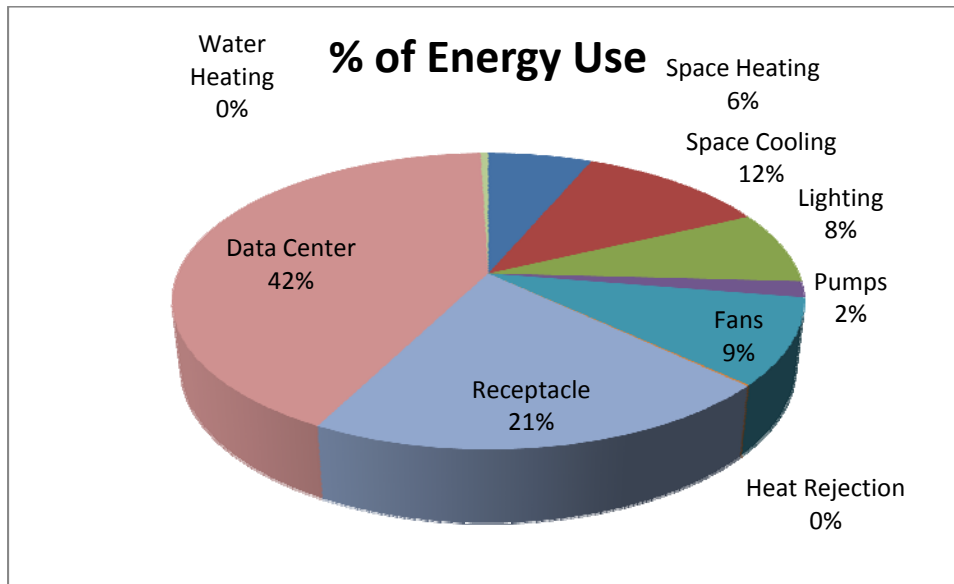

Figure 5

In addition to an annual consumption, monthly consumption was also computed with Trane TRACE 700. Table 13 shows the monthly consumption based on Peak, Mid-Peak, and Off-Peak hours for both natural gas and electricity.

Table 13

Monthly Energy Consumption												
Electric	Jan	Feb	Mar	Apr	May	June	July	Aug	Sept	Oct	Nov	Dec
On-Peak	173,817	156,484	184,873	178,873	196,423	200,688	204,045	209,045	188,896	188,099	179,185	174,730
Off-Peak	99,583	89,881	101,132	99,492	107,920	107,511	113,707	111,445	105,909	103,226	98,615	100,377
Mid-Peak	89,028	80,461	92,354	90,148	99,172	100,406	104,955	104,273	95,811	94,422	89,582	89,603
Data Center	780,333	780,333	780,333	780,333	780,333	780,333	780,333	780,333	780,333	780,333	780,333	780,333
Total	1,142,761	1,107,159	1,158,692	1,148,846	1,183,848	1,188,938	1,203,040	1,205,096	1,170,949	1,166,080	1,147,715	1,145,043
Gas												
On-Peak	383,200	350,100	225,000	140,500	71,100	43,700	34,700	46,000	66,800	151,200	180,100	289,400

The total consumption of electricity is highest in the summer while natural gas consumption is highest in the winter. Natural gas is used to heat the building and electricity is used to cool it. Figure 6 shows the modeled energy consumption graphically by month.

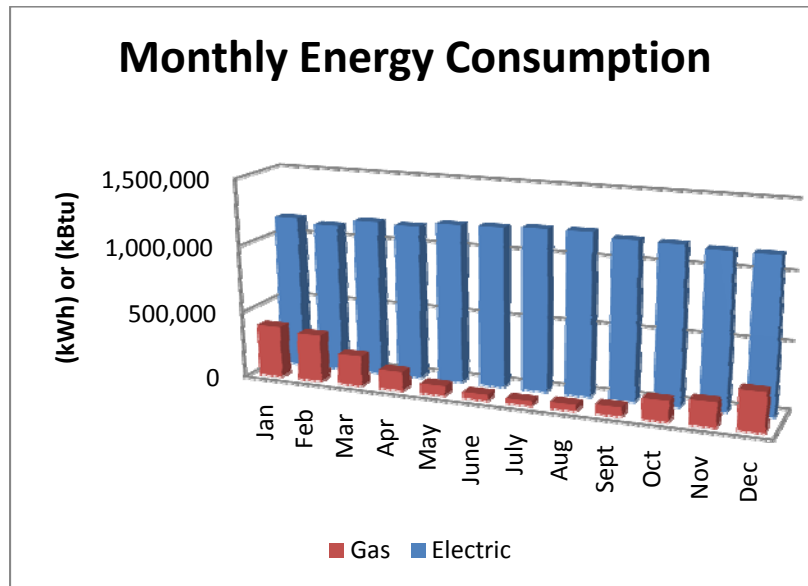

Figure 6

## LEED Analysis for the Mechanical Systems

LEED assessment was done for the DMA building using LEED-NC 2.2 by the engineers. LEED-NC 3.0 follows the same procedure except it gives more points for energy efficiency. There are two main categories for assessing the building's mechanical systems. They are Energy and Atmosphere, and Indoor Environmental Quality. The new version has 3 prerequisites for Energy and Atmosphere and 6 categories to earn credits. Indoor Environmental Quality has 2 prerequisites and 5 mechanical systems categories to earn credits in.

### Energy and Atmosphere

EA Prerequisite 1 is to have fundamental commissioning of the building energy systems which was done to achieve this prerequisite. EA Prerequisite 2 is meeting the minimum energy performance which was met and exceeded to get more points under EA Credit 1. EA Prerequisite 3 is refrigerant management where no CFC based refrigerants can be used in the building. The selected equipment will not use CFC based refrigerants.

EA Credit 1 is for evaluating energy performance. Based on the designer's submittal, the building will save around 15.5% of energy use over the baseline. This earns two credits under that category.

EA Credit 2 requires on-site renewable energy which the DMA Building doesn't have. Points range from 1 to 7 based on percentage of renewable energy generated on-site.

EA Credit 3 is worth two points and requires enhanced commissioning. Only basic commissioning will be done on this project.

EA Credit 4 is enhanced refrigerant management. The total refrigerant impact per ton must be less than 100. Based on the calculation done for this credit, the total refrigerant impact is only 51.7. This is worth two points.

EA Credit 5 is measurement and verification. Currently the building is just beginning construction, and if more points were needed, measurement and verification of the energy consumption can be done for an extra 3 points.

EA Credit 6 is buying at least 35% of the buildings electricity from green power for two years. This option is worth two points. Currently, the DMA Building is not going to buy renewable energy.

## Indoor Environmental Quality

EQ Prerequisite 1 requires ASHRAE 62.1 to be met for indoor air quality. Based on the calculations done for the earlier version of LEED by the engineer, this prerequisite is met. The calculated values done earlier for Technical Report One were off and required more outside air because of different assumptions of occupancy were made in the selected spaces.

EQ Prerequisite 2 is environmental tobacco smoke control. The DMA Building is a non-smoking building.

The credits associated with the mechanical systems are EQ C1, EQ C2, EQ C6.2, EQ C7.1, and EQ 7.2. The rest of the credits are associated with construction practices, electrical, and day lighting.

EQ Credit 1 is outdoor air delivery monitoring. CO2 monitoring must be done in every densely occupied space. This is worth 1 credit. Not all densely occupied spaces have CO2 sensors and therefore EQ Credit 1 was given.

EQ Credit 2 is increased ventilation. Increasing ventilation will increase energy consumption of the building. This was not done in the DMA Building.

EQ Credit 6.2 requires individual comfort control for 50% of the building occupants including multi-occupant spaces. This credit is not achieved because more than two offices in open spaces are served by the same VAV box.

EQ Credit 7.1 is design of thermal comfort. Based on the calculations done for EQ 7.1, Standard 55-2004 is satisfied and one point can be earned for this category.

EQ Credit 7.2 is the verification of thermal comfort. The owner of the building will conduct a thermal comfort survey one year after occupancy. Through the survey, verification of thermal comfort can be achieved for an additional point.

## Overall Evaluation

Overall, the mechanical system of the DMA Building is well planned out and implemented. Very efficient equipment is used to keep the energy usage of the building to a minimum. VAV systems combined with high efficiency chillers and boilers can be very effective if implemented correctly. VAV systems have been used in many office buildings and it is the most typical mechanical system used today.

The estimated construction cost for the mechanical system about 18% of the total cost. This is a typical cost of mechanical systems in office buildings. VAV systems are conventional and not too complicated to install and operate. The biggest costs and added value for this VAV system are the high efficiency chillers and boilers controlled by a DDC control system.

Operating cost of the building is quite high because of the type of loads in the building. The calculated operating cost is \$5.03/ft<sup>2</sup> a year. 67% of this cost is contributed by the data center. Cost of maintenance for this system should be relatively low. The system consists of only boilers, chillers, pumps AHU's and VAV boxes. It is a conventional system installed in many of today's buildings. Typical building engineers will know how to work on this type of system because there is no special maintenance or training that needs to be done.

Implementing a simple design with a DDC control system and high efficiency boilers and chillers was a good solution for this building. However there are a few improvements that could be made to minimize cost and further reduce energy consumption. The DMA Building is designed as a primary/secondary flow system. Utilizing variable flow chillers, a more efficient system can be made with very little changes.

There would be fewer pumps and their associated cost of installation. Switching to a different pumping system can improve the DMA Building's initial cost as well as further reducing energy consumption.

Another thing that was found was that only one cooling tower was utilized for free cooling. This building operates 24 hours a day and has very high internal loads on top of the data center. Currently waterside free cooling is only implemented for the data center. Converting the other two cooling towers to utilize free cooling can potentially reduce the loads further with a minimal initial cost.